

USW-PG | PG thread**Connectors**

Metal connector, safety-type, 90° elbow, PG outer thread, incl. ferrule [brass], sealing and O-ring [NBR]

Temperature: -40°C ... +125°C

Material: nickel-plated brass

IP class [acc. to EN 60529]: IP 67

for protective conduit: FLEXAgraft-SI-ASF

CHARACTERISTICS:

- Properties: highly watertight and dustproof
- friction-type locking of conduit and screw connector
- correct grounding
- covering of the conduit ends
- vibration- and tensionproof

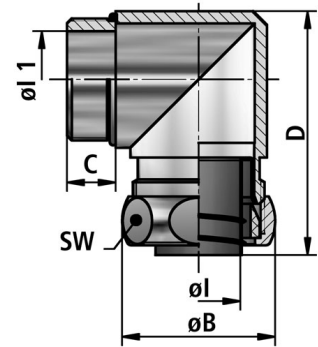
**APPLICATIONS:**

- Application: machine and plant constructions / automotive / railway industry / shipbuilding / automation / electrical installations

Recommended tightening torques pressure nut for IP 67

OD 10 (2 Nm) / OD 14 (5 Nm) / OD 17 (10 Nm) / OD 21 (15 Nm) / OD 27 (23 Nm) / OD 36 (34 Nm) / OD 45 (52 Nm) / OD 56 (70 Nm)



FIBIS
ELECTRO-PRODUCTS CORP.

FLEXA No.	OD [mm]	Thread type	Conduit ID	Conduit OD	Ø1 [mm]	ØB [mm]	C [mm]	D [mm]	WS [mm]	Weight [kg/100]	PU [pcs.]
15010237009	14,0	PG9	10,0	14,0	9,0	23,0	9,0	41,0	21	3,600	25
15010237011	17,0	PG11	12,0	17,0	10,5	27,0	8,0	45,0	25	5,900	25
15010235016	21,0	PG16	16,0	21,0	14,5	31,0	10,0	52,0	29	10,000	25
15010201021	27,0	PG21	21,0	27,0	19,5	39,0	10,5	58,0	36	13,400	10
15010237029	36,0	PG29	27,0	36,0	26,5	48,0	11,0	72,0	45	23,300	10

Recommendations for any areas of applications, products, or product combinations are issued to the best of FLEXA's knowledge and experience. The user is requested to check applicability of FLEXA products to specific applications and purposes prior to the use of the particular products. All documentation, illustrations, and charts published are subject to copyright and must not be copied, changed, used, or modified. Technical drawings, certificates, authorizations, and results by the FLEXA lab will be provided upon request. FLEXA will not be held liable for typographical or other errors and incorrect drawings. Technical modifications are subject to change without prior notice.