

USW-M | metric thread

Metal connector, safety-type, 90° elbow, metric outer thread, incl. ferrule [brass], sealing and O-ring [NBR]

Temperature: -40°C ... +125°C

Material: nickel-plated brass

IP class [acc. to EN 60529]: IP 67

for protective conduit: FLEXAgraft-SI-ASF

CHARACTERISTICS:

- Properties: highly watertight and dustproof
- friction-type locking of conduit and screw connector
- correct grounding
- covering of the conduit ends
- vibration- and tensionproof

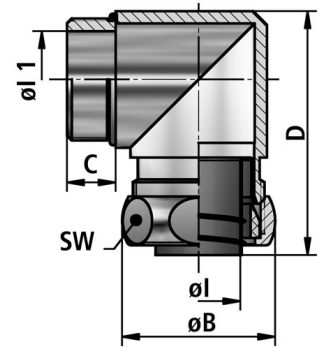
**APPLICATIONS:**

- Application: machine and plant constructions / automotive / railway industry / shipbuilding / automation / electrical installations

Recommended tightening torques pressure nut for IP 67

OD 10 (2 Nm) / OD 14 (5 Nm) / OD 17 (10 Nm) / OD 21 (15 Nm) / OD 27 (23 Nm) / OD 36 (34 Nm) / OD 45 (52 Nm) / OD 56 (70 Nm)



IBIS
ELECTRO-PRODUCTS CORP.

FLEXA No.	OD [mm]	Thread type	Conduit ID	Conduit OD	Ø l [mm]	Ø B [mm]	C [mm]	D [mm]	WS [mm]	Weight [kg/100]	PU [pcs.]
15010537016	14,0	M16 x 1,5	10,0	14,0	9,0	23,0	8,0	36,0	21	3,600	25
15010537020	17,0	M20 x 1,5	12,0	17,0	10,5	27,0	8,0	38,0	25	5,900	25
15010535025	21,0	M25 x 1,5	16,0	21,0	14,5	31,0	10,0	45,0	29	10,000	25
15010501032	27,0	M32 x 1,5	21,0	27,0	19,5	39,0	10,0	57,0	36	13,100	10
15010537040	36,0	M40 x 1,5	27,0	36,0	26,0	48,0	10,0	67,0	45	20,700	10
15010537050	45,0	M50 x 1,5	36,0	45,0	34,5	57,0	12,0	77,0	54	26,900	10
15010537063	56,0	M63 x 1,5	47,0	56,0	45,5	70,0	12,0	84,0	66	32,400	2

Recommendations for any areas of applications, products, or product combinations are issued to the best of FLEXA's knowledge and experience. The user is requested to check applicability of FLEXA products to specific applications and purposes prior to the use of the particular products. All documentation, illustrations, and charts published are subject to copyright and must not be copied, changed, used, or modified. Technical drawings, certificates, authorizations, and results by the FLEXA lab will be provided upon request. FLEXA will not be held liable for typographical or other errors and incorrect drawings. Technical modifications are subject to change without prior notice.