

US-M | metric thread

Connectors

Metal connector, safety-type, straight, metric outer thread, incl. ferrule [brass | plastics], sealing [TPE] and O-ring [NBR]

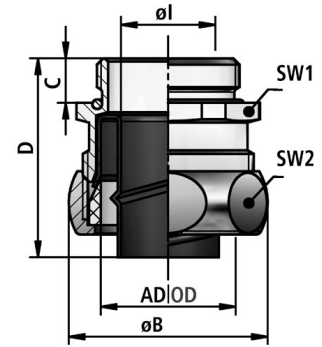

Temperature:	-40°C ... +125°C
Material:	nickel-plated brass
IP class [acc. to EN 60529]:	IP 67
for protective conduit:	FLEXAgraft-SI-ASF

CHARACTERISTICS:

- Properties: highly watertight and dustproof
- friction-type locking of conduit and screw connector
- correct grounding
- covering of the conduit ends
- vibration- and tensionproof

APPLICATIONS:

- Application: machine and plant constructions / automotive / railway industry / shipbuilding / automation / electrical installations

Recommended tightening torques pressure nut for IP 67

OD 10 (2 Nm) / OD 14 (5 Nm) / OD 17 (10 Nm) / OD 21 (15 Nm) / OD 27 (23 Nm) / OD 36 (34 Nm) / OD 45 (52 Nm) / OD 56 (70 Nm)



FLEXA No.	OD [mm]	Thread type	Conduit ID	Conduit OD	ø I [mm]	ø B [mm]	C [mm]	D [mm]	WS1 [mm]	WS2 [mm]	Weight [kg/100]	PU [pcs.]
15010337012	14,0	M12 x 1,5	10,0	14,0	9,0	23,0	10,0	33,0	19	21	2,140	50
15010337016	17,0	M16 x 1,5	12,0	17,0	10,5	27,0	10,0	33,0	23	25	3,000	50
15010335020	21,0	M20 x 1,5	16,0	21,0	14,5	31,0	10,0	33,0	27	29	3,940	50
15010301025	27,0	M25 x 1,5	21,0	27,0	19,5	39,0	11,0	41,0	34	36	7,500	25
15010337032	36,0	M32 x 1,5	27,0	36,0	25,5	48,0	14,0	43,0	43	45	11,300	25
15010337040	45,0	M40 x 1,5	36,0	45,0	35,0	57,0	13,0	43,0	52	54	15,000	20
15010337050	56,0	M50 x 1,5	47,0	56,0	45,0	70,0	15,5	49,0	63	66	21,800	10
15010337163	56,0	M63 x 1,5	47,0	56,0	45,0	74,0	14,0	49,0	70	70	27,100	10

Recommendations for any areas of applications, products, or product combinations are issued to the best of FLEXA's knowledge and experience. The user is requested to check applicability of FLEXA products to specific applications and purposes prior to the use of the particular products. All documentation, illustrations, and charts published are subject to copyright and must not be copied, changed, used, or modified. Technical drawings, certificates, authorizations, and results by the FLEXA lab will be provided upon request. FLEXA will not be held liable for typographical or other errors and incorrect drawings. Technical modifications are subject to change without prior notice.