

RQF2-M

Connectors FLEXAquick for ROHRflex corrugated plastic tubings

Plastic connector, quick-type. elbow flange 90° incl. flange-sealing

Temperature: -40°C ... +120°C

Material: PA plastics

CHARACTERISTICS:

- Properties: resistant against oil and benzine
- widely resistant to acids and solvents
- free of silicone, cadmium, halogen

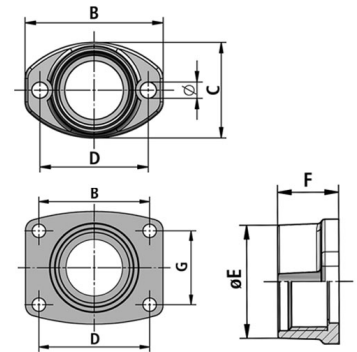
APPLICATIONS:

- Application: machine and plant constructions / automation / electrical installations



| FLEXA No. | Colour | Thread type | B [mm] | C [mm] | D [mm] | G [mm] | Ø [mm] | Ø E [mm] | H [mm] | F [mm] | Weight [kg/100] | PU [pcs.] |
|-------------|--------|-------------|--------|--------|--------|--------|--------|----------|--------|--------|-----------------|-----------|
| 15020071225 | Black | M25 x 1,5 | 46,0 | 32,0 | 36,0 | | 5,4 | 29,5 | 13,0 | 15,5 | 0,660 | 50 |
| 15020071232 | Black | M32 x 1,5 | 63,0 | 46,0 | 52,0 | | 6,6 | 37,0 | 16,5 | 20,0 | 1,480 | 25 |
| 15020071240 | Black | M40 x 1,5 | 67,0 | 55,0 | 54,0 | 36,0 | 6,6 | 29,5 | 16,0 | 18,5 | 1,900 | 10 |
| 15020071250 | Black | M50 x 1,5 | 86,0 | 64,0 | 73,0 | 30,0 | 6,6 | 55,0 | 17,0 | 20,0 | 2,500 | 10 |
| 15020071263 | Black | M63 x 1,5 | 86,0 | 70,0 | 73,0 | 30,0 | 6,6 | 68,0 | 17,0 | 20,0 | 2,500 | 5 |
| 15020071025 | Grey | M25 x 1,5 | 46,0 | 32,0 | 36,0 | | 5,4 | 29,5 | 13,0 | 15,5 | 0,660 | 50 |
| 15020071032 | Grey | M32 x 1,5 | 63,0 | 46,0 | 52,0 | | 6,6 | 37,0 | 16,5 | 20,0 | 1,480 | 25 |
| 15020071040 | Grey | M40 x 1,5 | 67,0 | 55,0 | 54,0 | 36,0 | 6,6 | 45,0 | 16,0 | 18,5 | 1,900 | 10 |
| 15020071050 | Grey | M50 x 1,5 | 86,0 | 64,0 | 73,0 | 30,0 | 6,6 | 55,0 | 17,0 | 20,0 | 2,500 | 10 |
| 15020071063 | Grey | M63 x 1,5 | 86,0 | 70,0 | 73,0 | 30,0 | 6,6 | 68,0 | 17,0 | 20,0 | 2,500 | 5 |

Recommendations for any areas of applications, products, or product combinations are issued to the best of FLEXA's knowledge and experience. The user is requested to check applicability of FLEXA products to specific applications and purposes prior to the use of the particular products. All documentation, illustrations, and charts published are subject to copyright and must not be copied, changed, used, or modified. Technical drawings, certificates, authorizations, and results by the FLEXA lab will be provided upon request. FLEXA will not be held liable for typographical or other errors and incorrect drawings. Technical modifications are subject to change without prior notice.