

## KSK-P | PG thread

## Accessories

Cable gland with PG thread

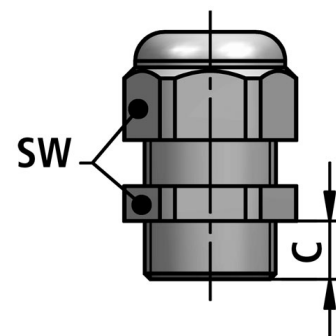

Temperature:	-20°C ... +100°C ^ +130°C
--------------	---------------------------

Material:	polyamide
-----------	-----------

IP class [acc. to EN 60529]:	IP 68
------------------------------	-------

## CHARACTERISTICS:

- Properties: resistant against light acids and soft lyes
- resistant against sea water, benzine and mineral oil



FLEXA No.	Outer thread	Colour	cable-Clamp.range [mm]	C [mm]	WS [mm]	Weight [kg/100]	PU [pcs.]
10321000207	PG7	Black	3-6,5	8,0	15	0,400	100
10321000209	PG9	Black	4-8,0	8,0	19	0,590	100
10321000211	PG11	Black	5-10,0	8,0	22	0,820	100
10321000213	PG13, 5	Black	6-12,0	9,0	24	0,950	100
10321000216	PG16	Black	10-14,0	10,0	27	1,220	50
10321000221	PG21	Black	13-18,0	11,0	33	2,120	50
10321000229	PG29	Black	18-25,0	11,0	42	3,720	25
10321000236	PG36	Black	22-32,0	13,0	53	6,900	10
10321000248	PG48	Black	34-44,0	14,0	65	9,600	5
10321000007	PG7	Grey	3-6,5	8,0	15	0,400	100
10321000009	PG9	Grey	4-8,0	8,0	19	0,590	100
10321000011	PG11	Grey	5-10,0	8,0	22	0,820	100
10321000013	PG13, 5	Grey	6-12,0	9,0	24	0,950	100
10321000016	PG16	Grey	10-14,0	10,0	27	1,220	50
10321000021	PG21	Grey	13-18,0	11,0	33	2,120	50
10321000029	PG29	Grey	18-25,0	11,0	42	3,720	25
10321000036	PG36	Grey	22-32,0	13,0	53	6,900	10
10321000048	PG48	Grey	34-44,0	14,0	65	9,600	5

Recommendations for any areas of applications, products, or product combinations are issued to the best of FLEXA's knowledge and experience. The user is requested to check applicability of FLEXA products to specific applications and purposes prior to the use of the particular products. All documentation, illustrations, and charts published are subject to copyright and must not be copied, changed, used, or modified. Technical drawings, certificates, authorizations, and results by the FLEXA lab will be provided upon request. FLEXA will not be held liable for typographical or other errors and incorrect drawings. Technical modifications are subject to change without prior notice.